

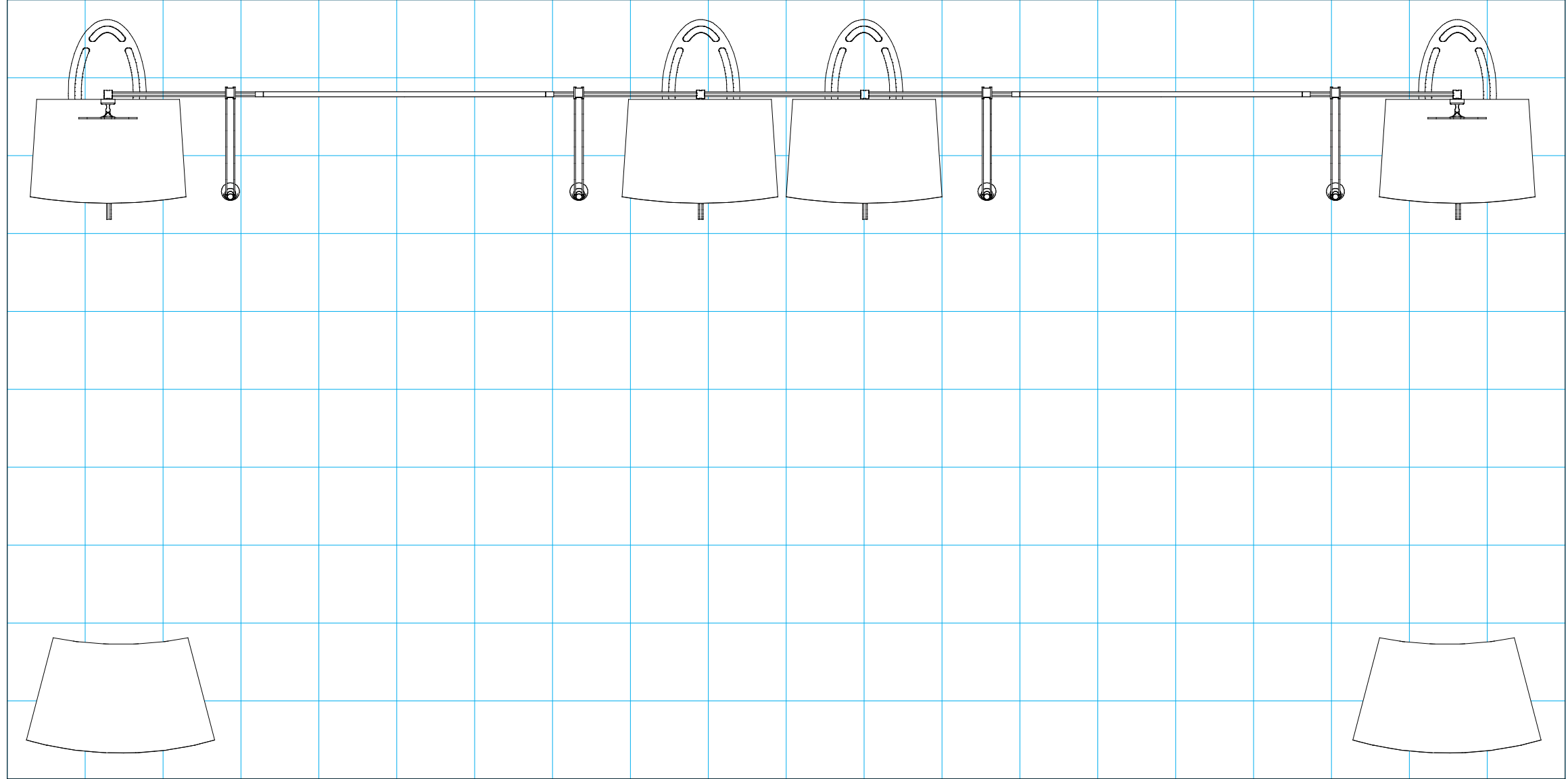

SETUP INSTRUCTIONS



 = 1 sq foot

General Setup Instructions

- Read entire setup instruction manual prior to unpacking parts and pieces.
- The setup instructions are created specifically for this configuration.
- Setup instructions are laid out sequentially in steps, including exploded views with detailed explanation for assembly.

Cleaning & Packing

- For Cleaning Metal, Plex, & Laminate Parts: Use a **MILD NON-ABRASIVE** cleanser and soft cloth/paper towel to clean all surfaces.
- Keep exhibit components away from heat and prolonged sun exposure.
Heat and UV exposure will warp and fade components.
- Retain all provided Packing Materials. All provided packing materials are for ease of repacking & component protection.

Disassembly

- For loss prevention, tighten all set screws and locks during disassembly.

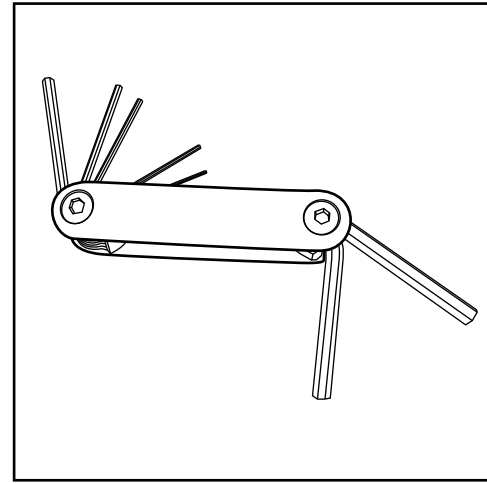

Hex Tool - Essential for Assembly

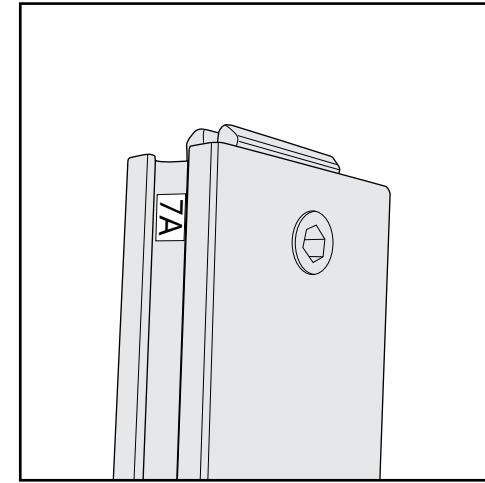

Part Identification - Numbering

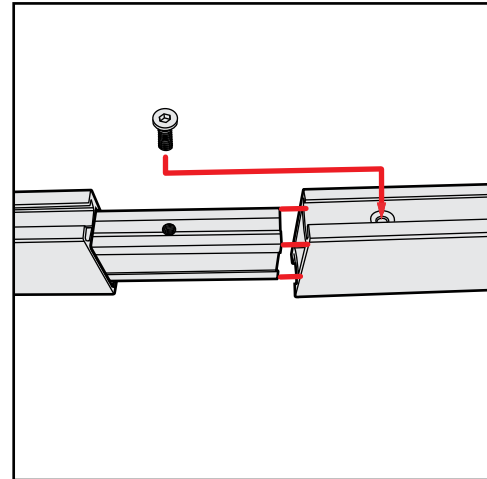

Spline Connection

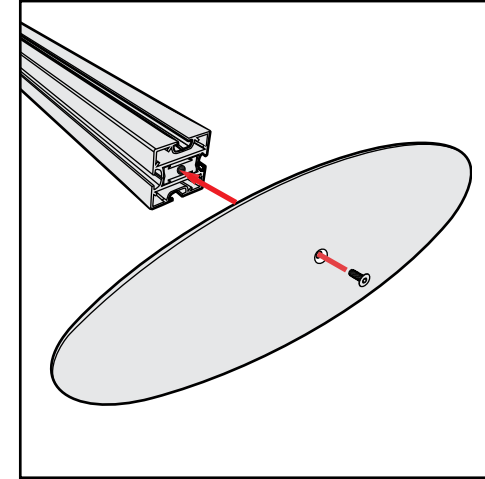

Base Plate & Extrusion Connection

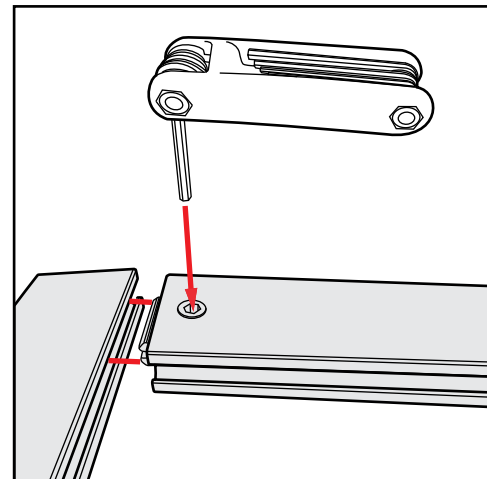

Extrusion & Lock Connection

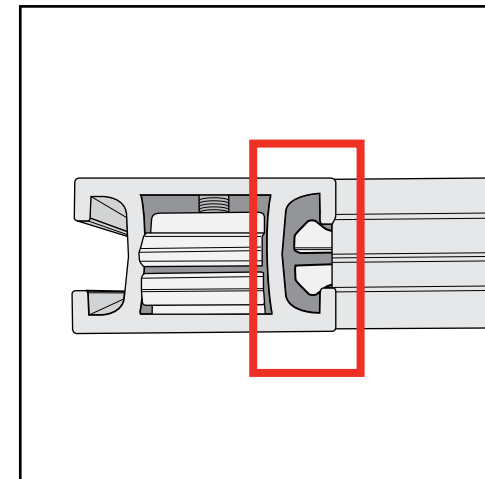

Engaged Lock



WARNING



DO NOT USE POWER TOOLS

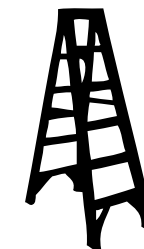

LADDERS OR LIFTS
MAY BE REQUIRED



ALL CONNECTIONS MUST
BE TIGHTLY SECURED



1) Mounting plate & wing nuts, in packed position.

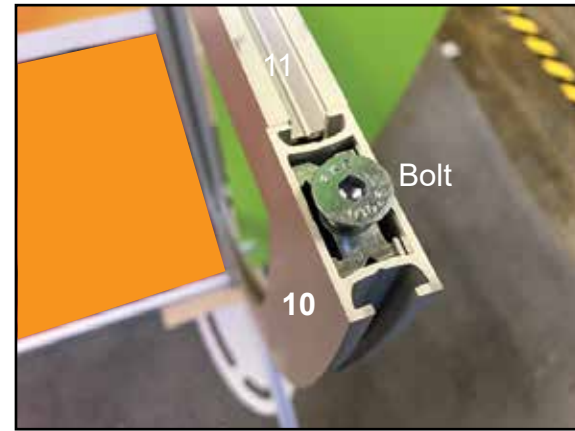

2) Mounting plate bolt in, packed position.

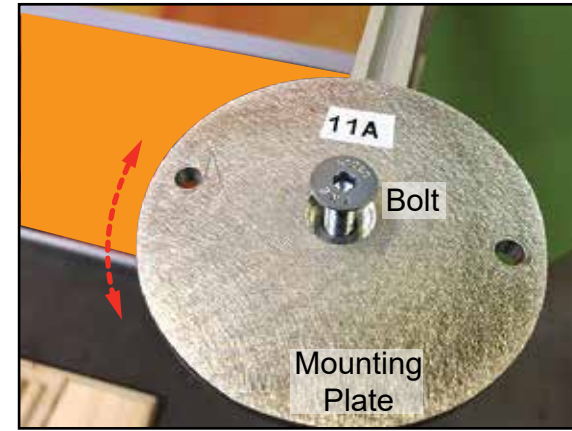

3) Place mounting plate onto [10] then tighten bolt, part way, allowing some rotation for final positioning.

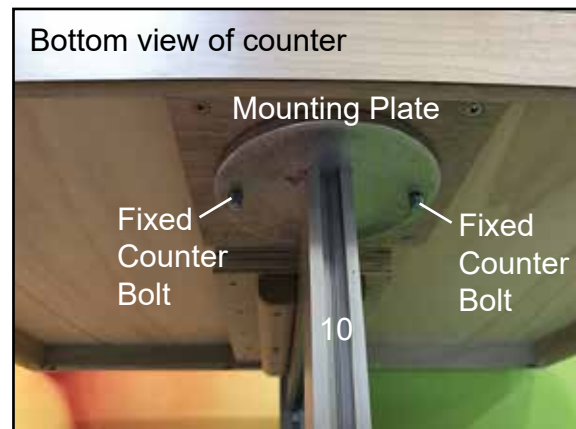

4) Place fixed counter bolts into mounting plate, then lift counter to re-tighten bolt.

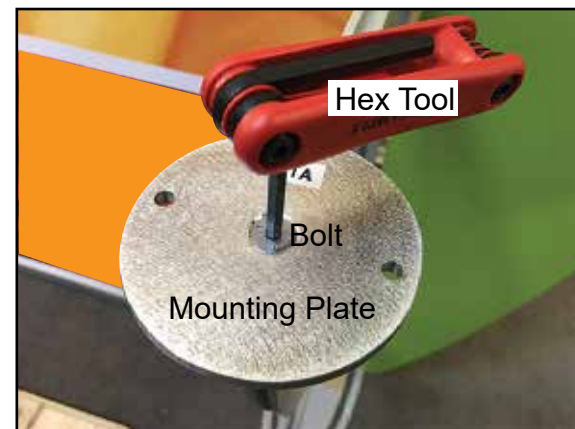

5) Tighten bolt, using hex tool, to secure.

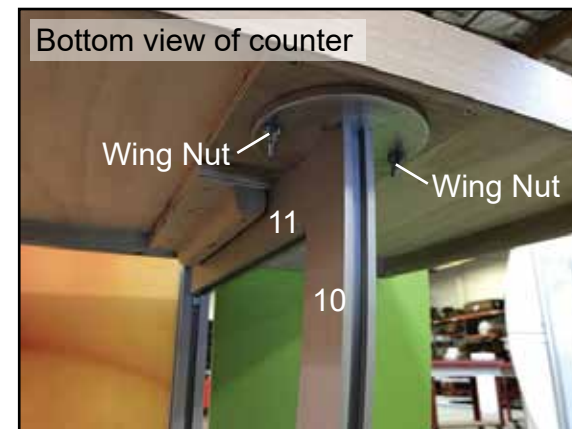

6) Place fixed counter bolts into mounting plate, then secure using wing nuts.

Completed Assembly

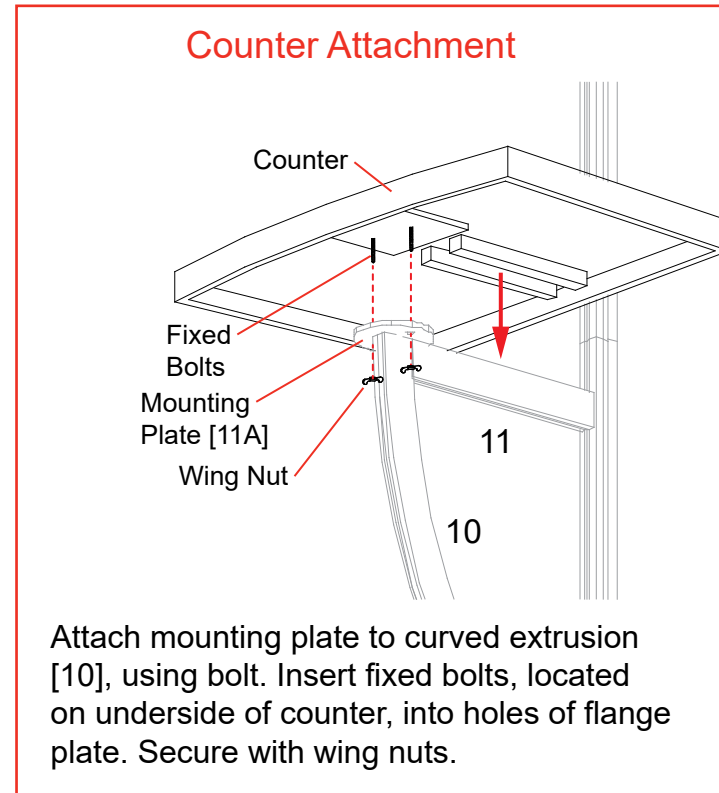

Keep mounting plate [11A] and wing nuts attached to counter, when packing.

Keep bolt attached to [10], when packing.

Top View of Each Level

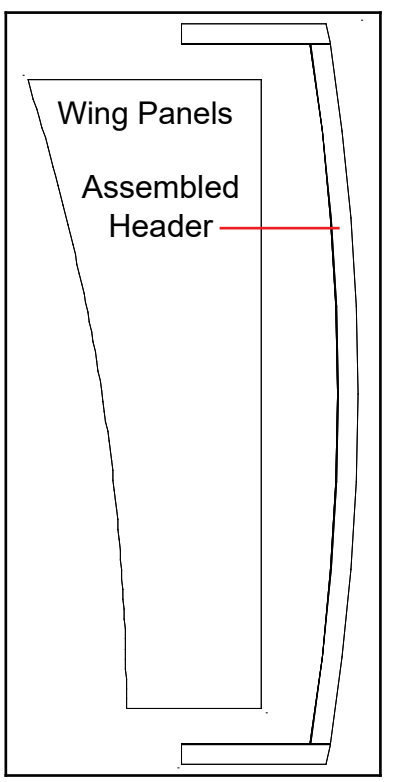

Level 1 (Bottom Level)

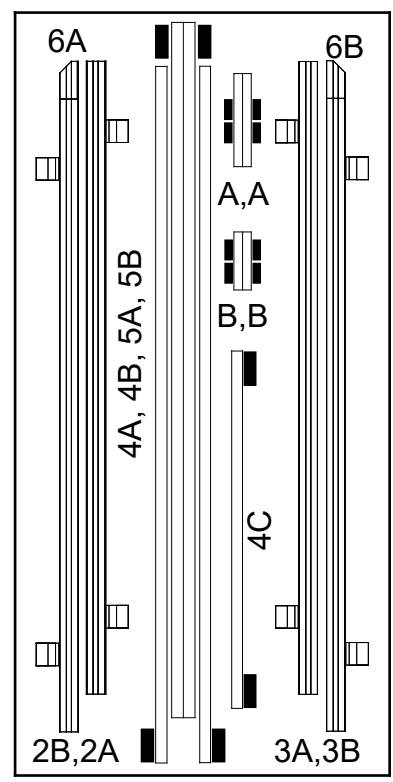

Level 2

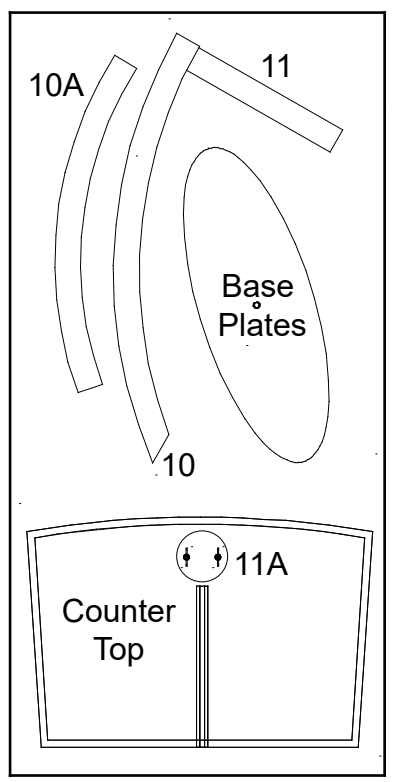

Level 3

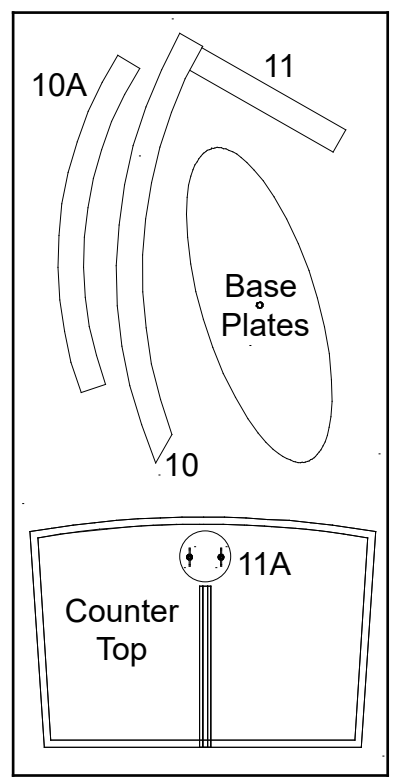

Level 4

Lights

Graphics

Setup Hardware
Shelf

Top View of Each Level

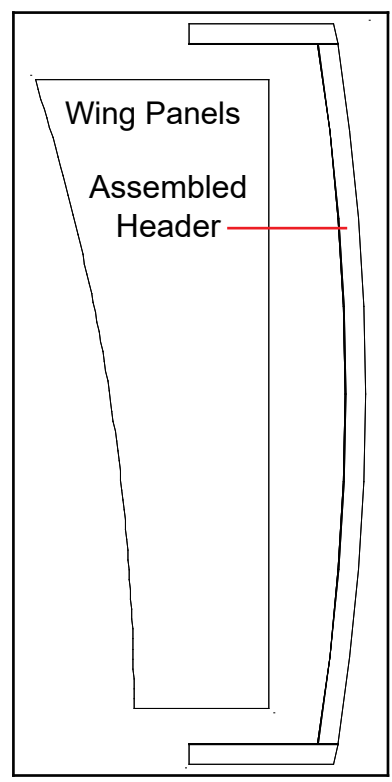

Level 1 (Bottom Level)

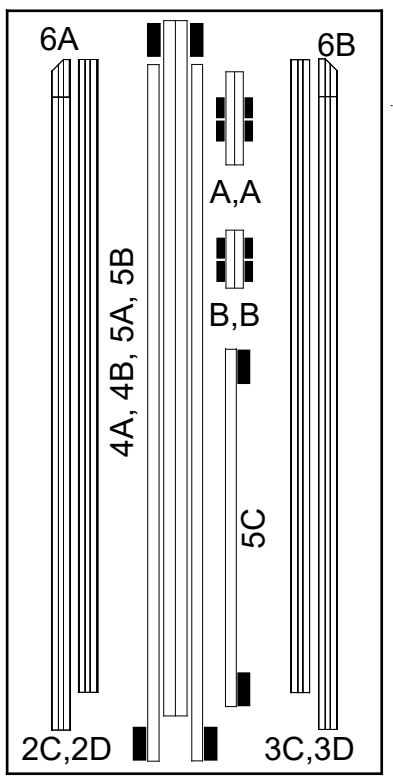

Level 2

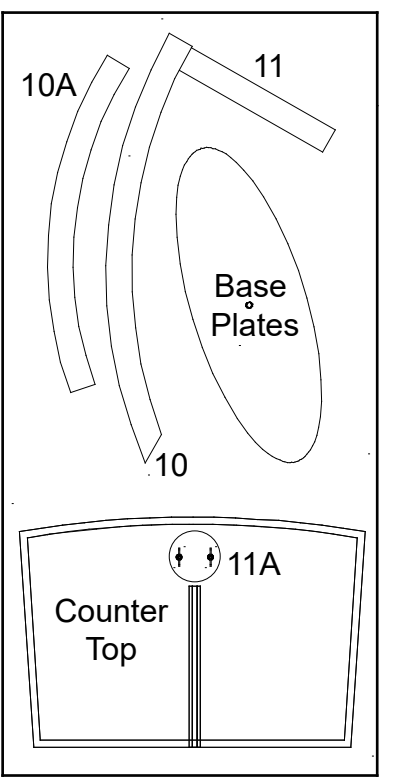

Level 3

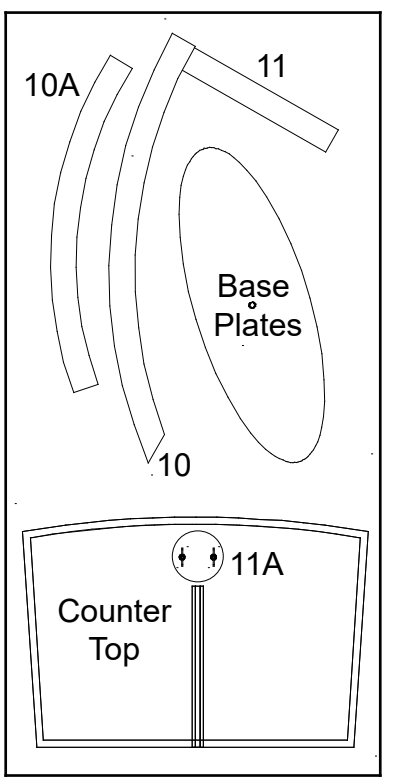

Level 4

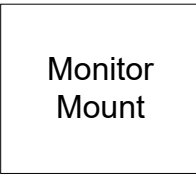
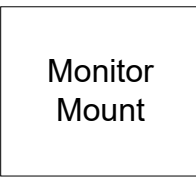

Top View of Each Level

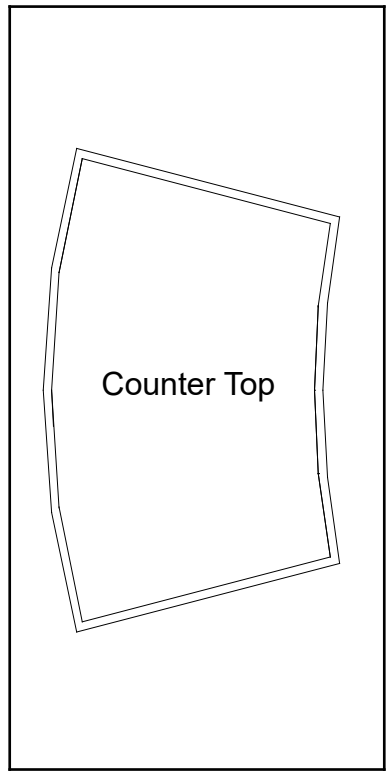

Level 1 (Bottom Level)

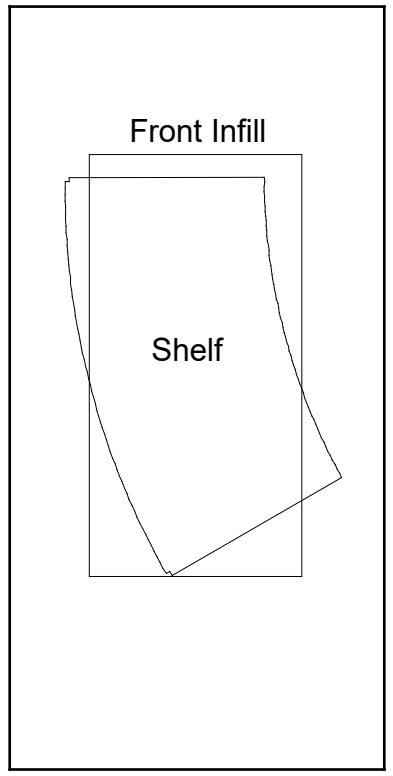

Level 2

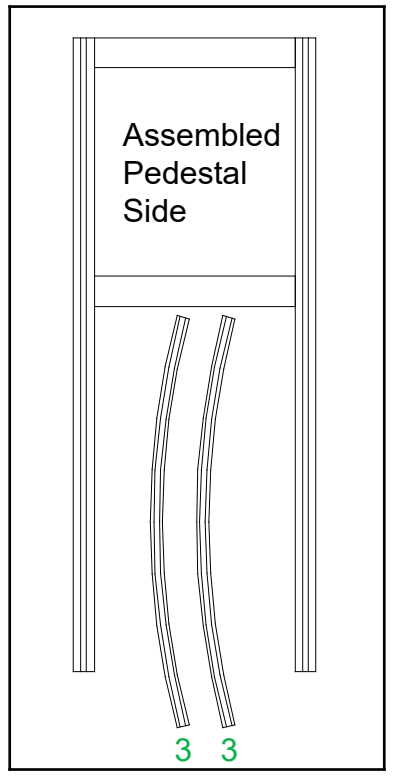

Level 3

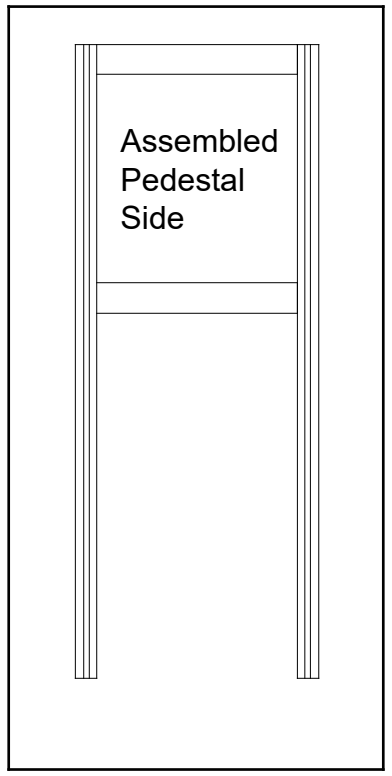

Level 4

Top View of Each Level

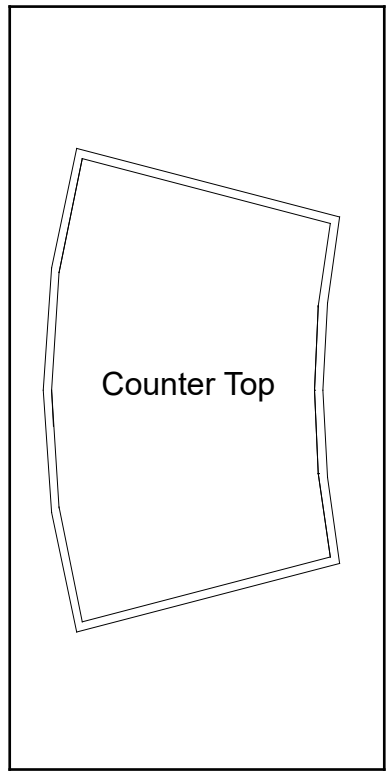

Level 1 (Bottom Level)

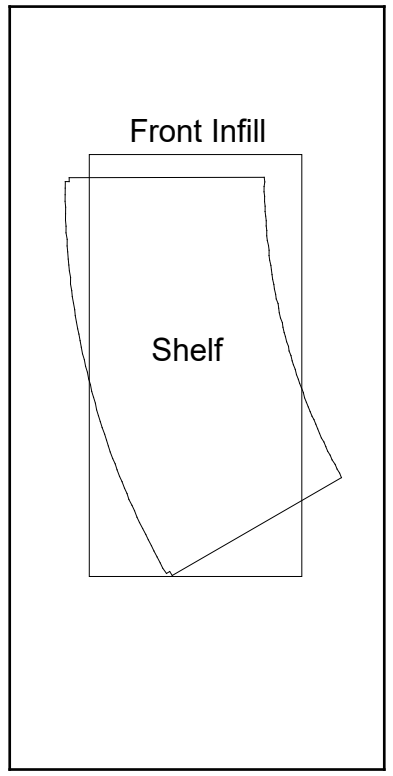

Level 2

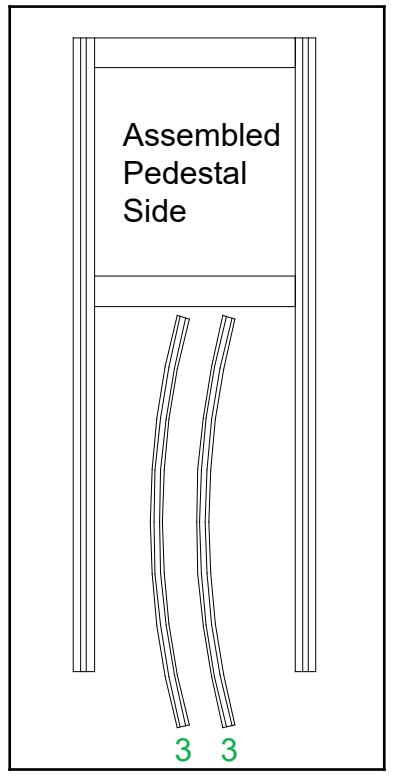

Level 3

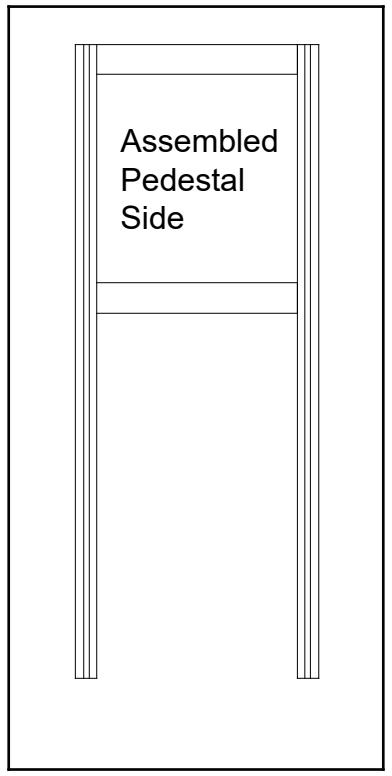

Level 4

| Item | Qty. | Description |
|-------|------|--|
| 1 | 2 | Base Plate |
| 2A,2B | 1,1 | 42" S40 Vertical Extrusion w/ A10 Clamps |
| 3A,3B | 1,1 | 42" S40 Vertical Extrusion w/ A10 Clamps |
| 2C,2D | 1,1 | 42" S40 Vertical Extrusion |
| 3C,3D | 1,1 | 42" S40 Vertical Extrusion |
| 4A,4B | 2,2 | 45" Z45 Horizontal Extrusion |
| 5A,5B | 2,2 | 45" Z45 Horizontal Extrusion |
| 4C,5C | 1,1 | 24" Z45 Horizontal Extrusion |
| 6A,6B | 2,2 | 2.5" S40 Angle-Cut Vertical |

- Steps:
- 1) Attach base plates [1] lower verticals [2A] [3A] [2C] and [3C], using bolts.
 - 2) Connect verticals [2A to 2B] [2C to 2D], [3A to 3B] and [3C to 3D], using connection bars [B]. See [Straight Connection with Knobs](#) detail.
 - 3) Connect horizontals [4A to 4B] and [5A to 5B], using connection bars [A]. See [Straight Connection with Knobs](#) detail.
 - 4) Attach vertical assemblies [2A/2B] [3A/3B] [2C/2D] and [3C/3D] with horizontal assemblies [4A/4B] and [5A/5B]. See [Corner Connection with Knob](#) detail.
 - 5) Connect extrusions [6A] and [6B] to verticals [2B] [2D] [3B] and [3D]. See [2.5" h Angle-Cut Vertical Attachment](#) detail.
 - 6) Connect left & right assemblies using horizontals [4C,5C].
 - 7) Attach graphic to Velcro on back of assembled Backwall.

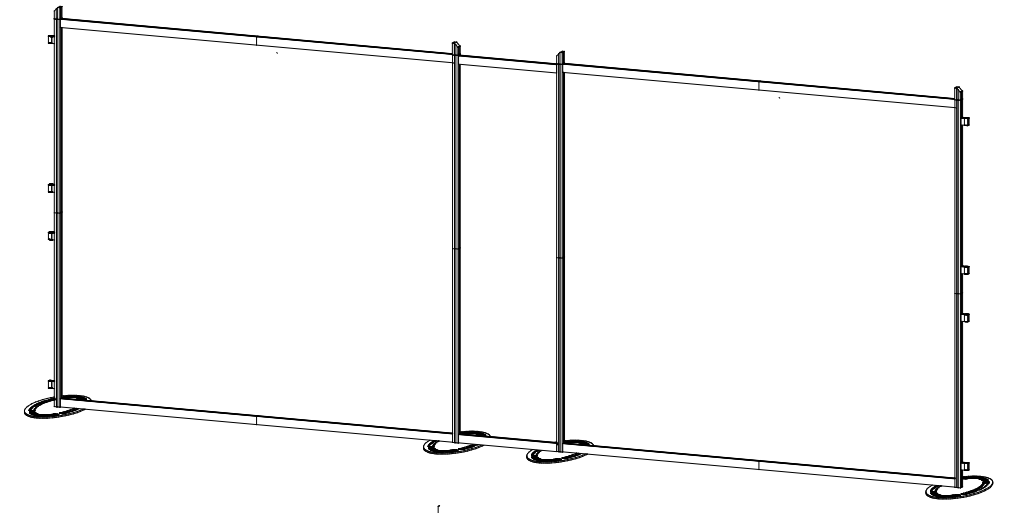

When Assembled

★ **Corner Connection with Knob**



Turn knob clockwise to tighten lock.

Do not over tighten Knobs

◆ **Straight Connection with Knobs**

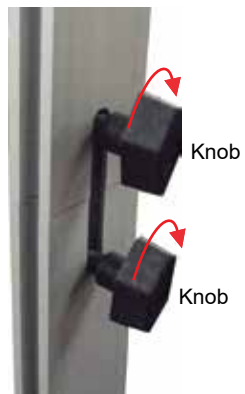

Slide connection bar between extrusions, then turn knobs clockwise to tighten lock.

Do not over tighten Knobs

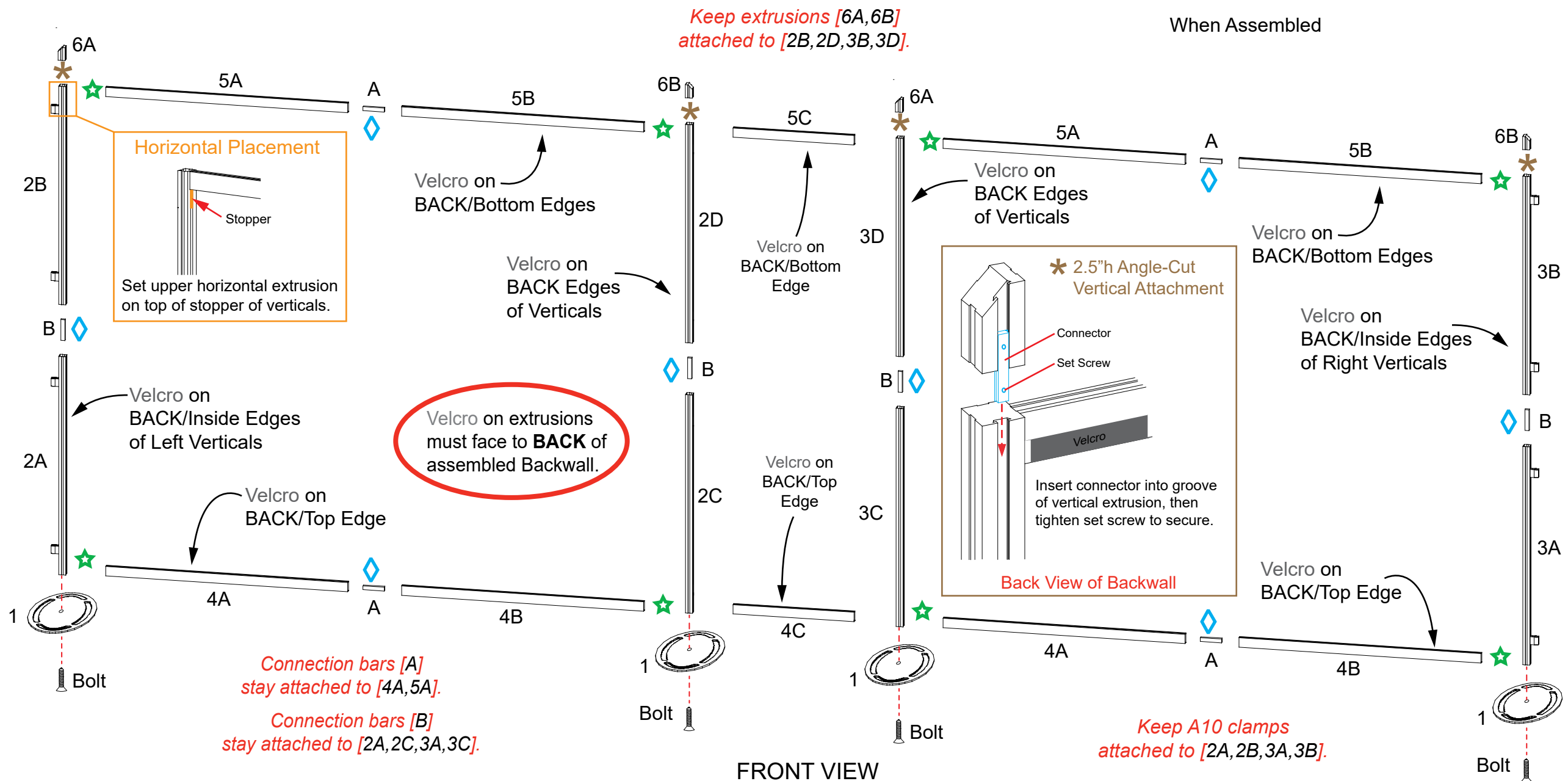

| Item | Qty | Description |
|------|-----|------------------------------|
| 1 | 8 | 38" S40 Vertical Extrusion |
| 2,2A | 4,4 | 12" Z45 Horizontal Extrusion |
| 3 | 4 | 25" Z45 Horizontal Extrusion |

Steps

- 1) Attach horizontals [2] and [2A] between verticals [1], with infills between.
- 2) Attach curved horizontals [3] between front verticals [1], with infill between.
- 3) Place shelf on lip of extrusions [2]. See [Extrusion Lip](#) detail.
- 4) Set pedestal top on top of extrusions [2A] and [3].

Repeat steps 1 through 4 for other pedestal assembly.

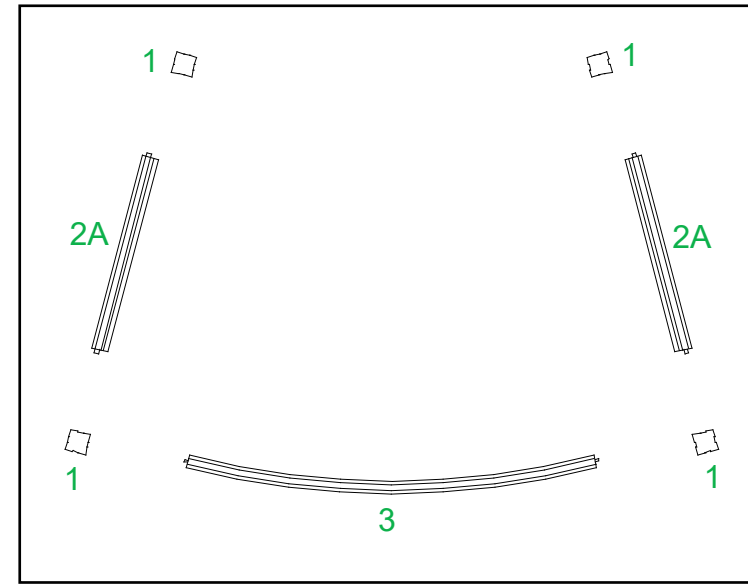

Top View

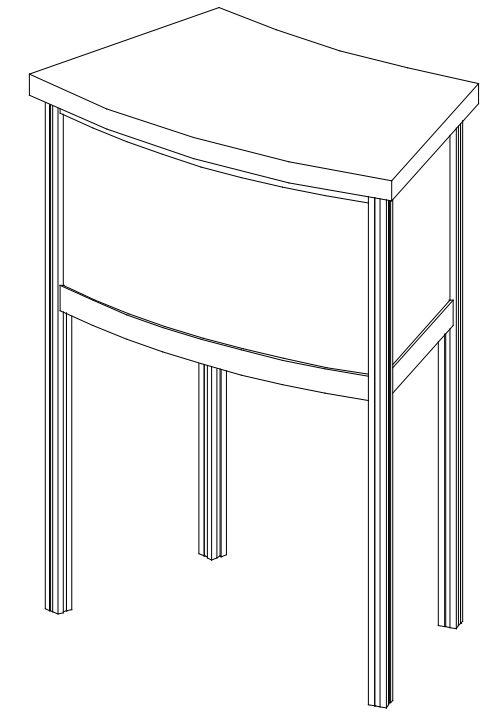

Completed Pedestal Assembly
Qty. 2

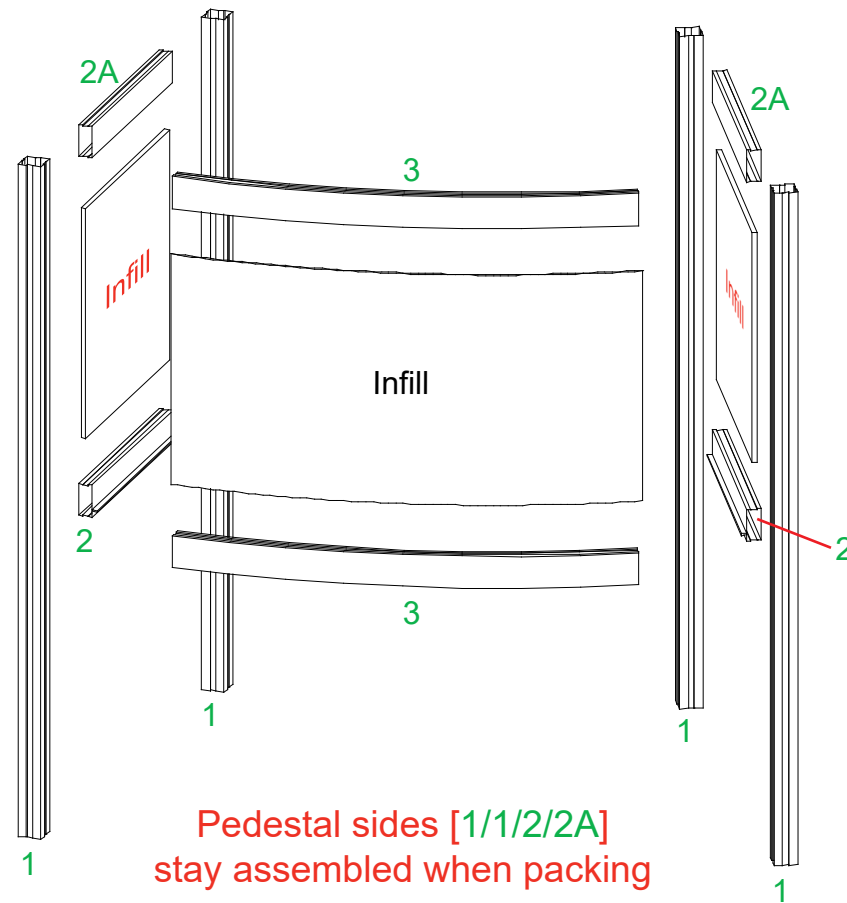

Pedestal sides [1/1/2/2A]
stay assembled when packing

